

Topic E Multiple Choice Questions

Questions on a gray background are for HL students

1. The diagram shows three energy levels of an atom.

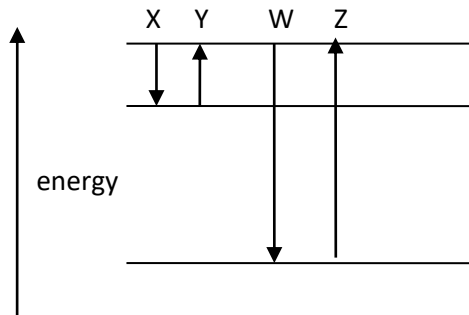

Which transitions represent the **absorption** of a photon of the largest wavelength and which to a photon of least wavelength?

	Largest wavelength	Least wavelength
A	Z	X
B	Y	Z
C	Z	Y
D	X	W

2. A hypothetical atom has four energy levels. How many transitions in which photons are emitted are possible?

A 4

B 6

C 8

D 10

3. A photon of energy 11.2 eV is incident on a hydrogen atom in the $n = 1$ state. What is correct about the energy of the scattered photon and the final state of the hydrogen atom? The energy in the $n = 1$ state is -13.6 eV and in the $n = 2$ the energy is -3.4 eV.

	Energy of scattered photon	Final state of hydrogen atom
A	11.2 eV	$n = 1$
B	10.2 eV	$n = 1$
C	7.8 eV	$n = 2$
D	1.0 eV	$n = 2$

4. Which of the following is **not** consistent with the Bohr model of hydrogen?

- A The electron can exist in discrete energy states.
- B Atomic spectra are the result of transitions between electron states.
- C The difference in energy between successive energy levels is constant.
- D A hydrogen atom can lose energy by emitting photons.

5. The absorption lines of visible light in the hydrogen spectrum involve transitions from $n = 2$ to higher states. Which statement is **not** correct about the effect of temperature on these lines?

- A Temperature has no effect on the presence of these lines.
- B There are no absorption lines at very low temperatures because most atoms are in the $n = 1$ state.
- C There are absorption lines only at moderate temperatures.
- D There are no absorption lines at very high temperatures because the atoms are ionized.

6. Two observations in the Rutherford scattering experiment are that most of the alpha particles went through with small deflections and very few suffered the large angle scatterings. What are the explanations for these observations in the Rutherford nuclear model?

	Reason for small deflections	Reason for large deflections
A	These alpha particles were very energetic.	The positive charge of the nucleus is much larger than that of the alpha particle.
B	The nucleus is so small that the probability that an alpha particle comes close to it is very small.	The density of the gold nucleus is much larger than the density of alpha particles.
C	The alpha particles suffer a very small number of collisions.	The alpha particles suffer a large number of collisions.
D	Most alpha particles never got close to the nucleus of the atom.	A few alpha particles got very close to the nucleus of the atom.

7. What is a typical value for the ratio $\frac{\text{size of an atom}}{\text{size of a nucleus}}$?

A 10^5

B 10^{10}

C 10^{-5}

D 10^{-10}

8. All of the following are valid conclusions from the Rutherford experiment **except** one. Which one?

- A** The nucleus is electrically charged.
B The nucleus is much smaller than the atom.
C The nucleus contains protons and neutrons.
D Most of the mass of the atom is in the nucleus.

9. The radius of the electron orbit in the n th state of hydrogen is $n^2 a_0$, where a_0 is the Bohr radius. An electron in the $n = 2$ state of hydrogen has speed v . What is the speed of the electron in the $n = 3$ state of hydrogen?

A $\frac{3v}{2}$

B $\frac{2v}{3}$

C $\frac{v}{2}$

D $\frac{v}{9}$

10. The radius of the electron orbit in the n th state of hydrogen is $n^2 a_0$, where a_0 is the Bohr radius. An electron in the $n = 1$ state of hydrogen makes f revolutions per second. How many revolutions per second does an electron in the $n = 3$ state of hydrogen make?

- A $27f$ B $9f$ C $\frac{f}{9}$ D $\frac{f}{27}$

11. What are the number of neutrons and the number of electrons in the neutral atom of ${}^{195}_{78}\text{Pt}$?

	Number of neutrons	Number of electrons
A	117	195
B	117	78
C	195	78
D	195	117

12. An element has two isotopes. What is correct about the proton number and the nucleon number of the isotopes?

	Proton number	Nucleon number
A	same	same
B	same	different
C	different	same
D	different	different

13. Three particles are:

I protons

II neutrons

III electrons

What particles are contained within radioactive nuclei?

A I and II

B I and III

C II and III

D I, II and III

14. A particle has mass 1800 MeV c^{-2} . What is the approximate value of this mass expressed in u?

- A 0.02 u B 0.2 u C 2 u D 20 u

15. The mass difference in a nuclear reaction is 0.05 u. What is an estimate of the energy released?

- A 50 MeV B 500 MeV C 500 J D $5 \times 10^{14} \text{ J}$

16. A particle has mass 100 MeV c^{-2} . What is the energy corresponding to this mass?

- A 100 MeV B $100 \times (3 \times 10^8)^2 \text{ MeV}$ C 100 J D $100 \times (3 \times 10^8)^2 \text{ J}$

17. The difference between the total mass of the nucleons and the mass of the nucleus is 0.01 u. What is an approximate value of the binding energy of this nucleus?

- A 90 MeV B 90 MeV c^{-2} C 9 MeV D 9 MeV c^{-2}

18. The binding energy per nucleon for $^{11}_5\text{B}$ is about 7 MeV. What is the minimum energy needed to separate the nucleons of $^{11}_5\text{B}$?

- A 7 MeV B 35 MeV C 42 MeV D 77 MeV

19. The mass of the nucleus of ^7_3Li is M . What is the binding energy per nucleon of ^7_3Li ?

- A $\frac{(3m_p + 4m_n - M)c^2}{7}$ B $\frac{(4m_p + 3m_n - M)c^2}{7}$ C $\frac{(3m_p + 7m_n - M)c^2}{10}$ D $\frac{(7m_p + 3m_n - M)c^2}{10}$

20. The binding energy of a nucleus is the minimum energy that must be provided

- A to extract one nucleon from the nucleus
 B to keep the nucleons together
 C to separate all the nucleons of the nucleus
 D to assemble the nucleons into the nucleus

21. Which is approximately the same for nuclei with nucleon number greater than about 20?

- A Binding energy per nucleon
 B Binding energy
 C Mass defect
 D Half-life

22. How would the decay of a nucleus of ${}_{27}^{60}\text{Co}$ into a nucleus of ${}_{28}^{60}\text{Ni}$ be described?

- A Alpha decay
- B Beta minus decay
- C Beta plus decay
- D Gamma decay

23. Magnesium ${}_{12}^{23}\text{Mg}$ decays into sodium ${}_{11}^{23}\text{Na}$. What other particles are produced in this decay?

- A A positron and an antineutrino
- B A positron and a neutrino
- C An electron and an antineutrino
- D An electron and a neutrino

24. What is the most likely decay of an unstable nucleus with too many neutrons?

- A Alpha decay.
- B Beta minus decay.
- C Beta plus decay.
- D Gamma decay.

25. What type of radiation has the greatest range in air and the most ionizing power in air?

	Range	Ionizing power
A	Gamma rays	Alpha particles
B	Alpha particles	Gamma rays
C	Beta particles	Alpha particles
D	Gamma rays	Beta particles

26. Radioactive decay is described as a *spontaneous* process. What does this mean?

- A We cannot predict which nucleus will decay next.
- B We cannot predict when a nucleus will decay.
- C We cannot predict accurately how many nuclei will decay in a given time interval.
- D We cannot influence the decay in any way.

27. The activity of a sample containing a radioactive element is 10000 Bq. After 48 minutes the activity is 625 Bq. What is the half-life of the sample?

- A 3.0 minutes B 8.0 minutes C 12 minutes D 16 minutes

28. A radioactive sample contains an element with a very long half life. The particles emitted move in all possible directions. A counter is placed at some distance from the sample. The distance of the counter from the sample is then increased. What changes, if any, take place in the activity and counter rate?

	Effect on activity	Effect on counter rate
A	none	none
B	none	decrease
C	decrease	none
D	decrease	decrease

29. A sample contains a small quantity of a radioactive element with a very long half-life. The temperature of the sample is increased. What are the effects, if any, on the half-life and activity of the sample?

	Effect on half-life	Effect on activity
A	none	none
B	none	increase
C	increase	none
D	increase	increase

30. A mass of 50 mg of a radioactive element is mixed with 100 mg of a stable element. The activity of the sample is 600 Bq. What will the activity be if the 50 mg of the radioactive element is mixed with 200 mg of the stable element?

- A 200 Bq B 240 Bq C 300 Bq D 600 Bq

31. A counter placed near a radioactive sample has a counter rate of 120 Bq. The background rate is 20 Bq. The half life of the sample is 6 days. What will be the counter rate after 12 days?

- A 20 Bq B 25 Bq C 30 Bq D 45 Bq

32. A pure radioactive sample has a half life of 5 minutes. The number of nuclei present in the sample initially is N . After how many minutes will $\frac{15}{16}N$ nuclei decay?

- A 10 B 15 C 20 D 80

33. The decay series for ${}^{226}_{88}\text{Ra}$ ends with ${}^{206}_{82}\text{Pb}$. The series contains 4 beta minus decays. How many alpha decays does it contain?

- A 2 B 4 C 5 D 10

34. In a decay series, a nucleus X decays by alpha decay to nucleus Y. Y decays by beta minus decay to nucleus Z and Z decays to nucleus W by beta minus decay. What can be said about a comparison of nucleus X with nucleus W?

- A X and W are identical nuclei
 B W has a greater proton number than X
 C W has a lower proton number than X
 D X and W are isotopes of the same element

35. Polonium (${}^{218}_{84}\text{Po}$) decays at rest by alpha decay into lead (${}^{214}_{82}\text{Pb}$). What is correct about the magnitude of the momentum and the kinetic energy of the alpha particle and the lead nucleus?

	Momentum	Kinetic energy
A	same	same
B	same	different
C	different	same
D	different	different

36. A radioactive isotope X decays into a stable isotope Y. After how many half-lives will the ratio of the number of Y nuclei to the number of X nuclei will be 7:1?

- A 2 B 3 C 5 D 7

37. Two radioactive samples X and Y have the same half-life. Initially, $\frac{\text{activity of X}}{\text{activity of Y}} = 4$. What is this ratio after 2 half lives?

- A 4 B 2 C 1 D $\frac{1}{2}$

38. The half- life of a pure sample of a radioactive isotope is 8 days. What fraction of the original mass of the sample remains after 20 days?

- A 18% B 25% C 30% D 35%

39. In the photoelectric effect, which change would result in electrons being emitted with a larger kinetic energy?

- A Increasing the wavelength of the incident light.
B Increasing the intensity of the incident light.
C Decreasing the area of the photo-surface.
D Decreasing the work function of the photo-surface.

40. Photons of energy 2.4 eV are incident on a metal surface of work function 1.8 eV and cause the emission of electrons.

What is the stopping voltage in this experiment?

- A 0.6 V B 0.6 eV C 4.2 V D 4.2 eV

41. Electromagnetic waves are incident on a metallic surface. Three statements are made:

- I Electrons may be emitted from the surface
II Any electrons emitted, are emitted with no time delay
III No electrons are emitted if the frequency of light is below a certain value

Which statements **cannot** be explained by the wave theory of light?

- A I and II
B I and III
C II and III
D I, II and III

42. Photons of energy E are incident on a metal surface and cause the emission of electrons of maximum kinetic energy K .

What is the longest wavelength of light that can cause emission of electrons from this surface?

A $\frac{E+K}{hc}$ B $\frac{E-K}{hc}$ C $\frac{hc}{E+K}$ D $\frac{hc}{E-K}$

43. Photons of energy 2.2 eV cause the emission of electrons of maximum kinetic energy K from a metal surface. Photons of energy 2.8 eV cause the emission of electrons of maximum kinetic energy $2K$ from the same metal surface.

What is the work function of the surface?

A 0.3 eV B 0.6 eV C 1.6 eV D 2.5 eV

44. Light is incident on a metal surface causing the emission of electrons. The frequency of the light is increased keeping the intensity of light incident on the surface constant. What happens to the current that leaves the surface and the kinetic energy of the electrons emitted?

	Current	Kinetic energy
A	increases	increases
B	increases	stays the same
C	decreases	increases
D	decreases	stays the same

45. A photo-surface is on board a spacecraft that is moving away from the Sun. The light incident on the photo-surface is passed through a filter so that the light incident on the photo-surface is monochromatic. What changes occur to the current and the kinetic energy of the emitted electrons?

	Current	Kinetic energy
A	stays the same	stays the same
B	stays the same	decreases
C	decreases	stays the same
D	decreases	decreases

46. Photons of energy 3.0 eV are incident on a metal surface of work function 1.8 eV. The potential difference between the metal surface and the collecting plate is 0.9 V.

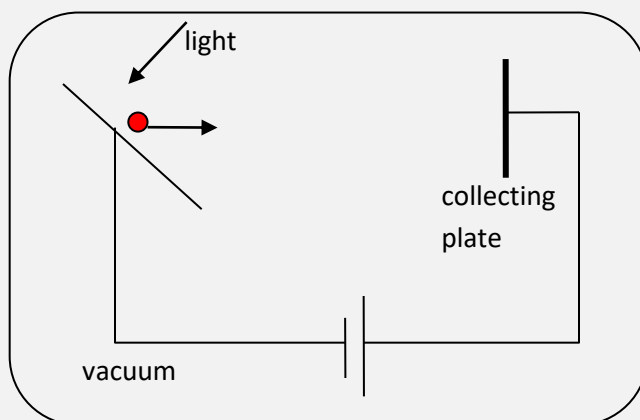

What is the maximum kinetic energy of the electrons at the collecting plate?

- A 0.3 eV B 2.1 eV C 2.7 eV D 3.9 eV
47. Light of wavelength λ and intensity I is incident on a metallic surface and electrons are emitted. Which of the following change will, by itself, result in a greater number of electrons being emitted?
- A increase λ B decrease λ C increase I D decrease I
48. Photons of wavelength λ are incident normally on a metallic surface and are reflected without loss of energy. There are N photons incident per unit time per unit area. What is the pressure exerted by the photons on the surface?
- A $\frac{Nh}{\lambda}$ B $\frac{2Nh}{\lambda}$ C $\frac{Nhc}{\lambda}$ D $\frac{2Nhc}{\lambda}$
49. Light is incident on a photosurface. The stopping voltage is V_s . The wavelength of the light is halved. What is the new stopping voltage?
- A V_s B between V_s and $2V_s$ C $2V_s$ D greater than $2V_s$
50. Which of the following phenomena is explained by the wave nature of electromagnetic radiation?
- A Electron diffraction.
 B The photoelectric effect.
 C Atomic spectra.
 D Diffraction.

51. The radius of the electron in the $n = 1$ orbit of hydrogen is a_0 . What is the de Broglie wavelength of this electron?

- A $2\pi a_0$ B πa_0 C $\frac{h}{a_0}$ D $\frac{a_0}{h}$

52. Electrons accelerated from rest by a potential difference V have a de Broglie wavelength λ . What is the de Broglie wavelength of electrons that have been accelerated from rest by a potential difference $4V$?

- A 4λ B 2λ C $\frac{\lambda}{2}$ D $\frac{\lambda}{4}$

53. A particle of mass m has de Broglie wavelength λ . What is the kinetic energy of the particle?

- A $\frac{\lambda^2}{2mh^2}$ B $\frac{\lambda}{2mh}$ C $\frac{h}{2m\lambda}$ D $\frac{h^2}{2m\lambda^2}$

54. Which experiment demonstrates the wave nature of electrons?

- A The Thomson charge to mass experiment.
 B The Millikan quantization of charge experiment.
 C The Rutherford scattering experiment.
 D The Davisson-Germer experiment.

55. A proton accelerated from rest by a potential difference has de Broglie wavelength λ . What is the de Broglie wavelength of an alpha particle accelerated from rest by the same potential difference?

- A $\frac{\lambda}{4}$ B $\frac{\lambda\sqrt{2}}{4}$ C $\frac{\lambda}{2}$ D $\frac{\lambda\sqrt{2}}{2}$

56. At which scattering angle does the maximum wavelength shift in Compton scattering occur?

- A 0° B 45° C 90° D 180°

57. A photon of wavelength λ scatters off an electron at rest. The scattered photon has wavelength λ' . What is the fraction of the incident photon energy that gets transferred to the electron?

- A $\frac{\lambda' - \lambda}{\lambda}$ B $\frac{\lambda' - \lambda}{\lambda'}$ C $\frac{\lambda}{\lambda'}$ D $\frac{\lambda'}{\lambda}$

58. Photons of energy 40 keV and 60 keV scatter off electrons at rest. The scattering angles are the same. How do the wavelength shifts, $\Delta\lambda$, and energy transferred to the electrons, ΔE , compare?

	$\Delta\lambda$	ΔE
A	$\Delta\lambda_{40} > \Delta\lambda_{60}$	$\Delta E_{40} > \Delta E_{60}$
B	$\Delta\lambda_{40} < \Delta\lambda_{60}$	$\Delta E_{40} < \Delta E_{60}$
C	$\Delta\lambda_{40} = \Delta\lambda_{60}$	$\Delta E_{40} > \Delta E_{60}$
D	$\Delta\lambda_{40} = \Delta\lambda_{60}$	$\Delta E_{40} < \Delta E_{60}$

59. Protons and neutrons have approximately the same mass. A proton and a neutron move in the direction of a uniform electric field. At X, they have the same kinetic energy and de Broglie wavelength.

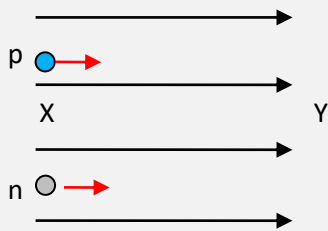

The potential difference between X and Y is very large. Which is a correct comparison of the kinetic energy and de Broglie wavelength of the proton and the neutron at Y?

	Kinetic energy	de Broglie wavelength
A	same	same
B	same	different
C	different	same
D	different	different

65. The role of the moderator in a nuclear fission reactor is to

- A control the rate of reactions.
- B to limit the number of neutrons causing fission reactions.
- C slow down the produced neutrons.
- D make sure that no radiation escapes the core of the reactor.

66. An alpha particle is directed at a fixed nucleus of gold -197. The distance of closest approach is d . An alpha particle with the same energy is now directed at a nucleus of gold-195. What is the distance of closest approach?

- A $\frac{195}{197}d$ B $d\sqrt{\frac{195}{197}}$ C d D $\frac{197}{195}d$

67. The radius of the nucleus ${}^9_4\text{Be}$ is R . What is the radius of the nucleus ${}^{72}_{32}\text{Ge}$?

- A $2R$ B $3R$ C $4R$ D $8R$

68. Nuclei have approximately the same

- A density.
- B binding energy.
- C binding energy per nucleon.
- D neutron to proton ratio.

69. Under what changes will deviations from Rutherford scattering likely to be observed?

	Proton number of target nuclei	Energy of incident alpha particles
A	increases	increases
B	increases	decreases
C	decreases	increases
D	decreases	decreases

74. The graph shows how the number of nuclei N of a radioactive sample varies with time t .

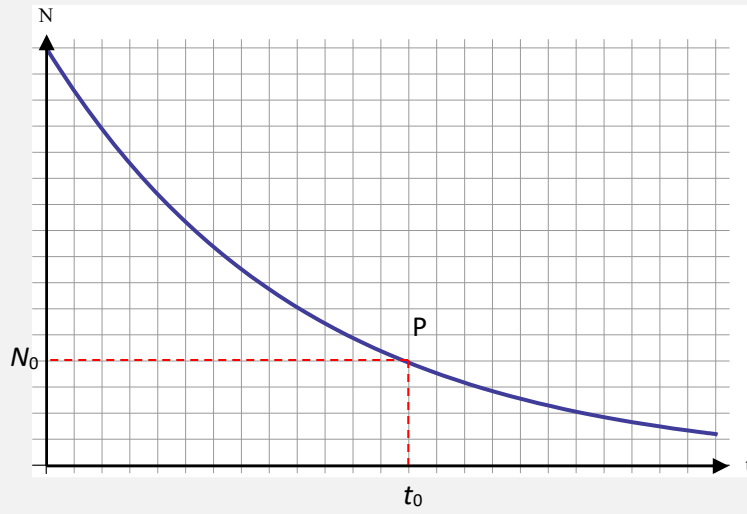

The gradient of the graph at P is G . What is $\frac{G}{N_0}$ equal to?

- A The activity at $t = t_0$.
- B The half-life.
- C The decay constant.
- D The fraction of the nuclei that have decayed by time t_0 .

75. The activity of a pure radioactive sample is A when the number of nuclei present in the sample is N . Which graph shows the variation of A with N ?

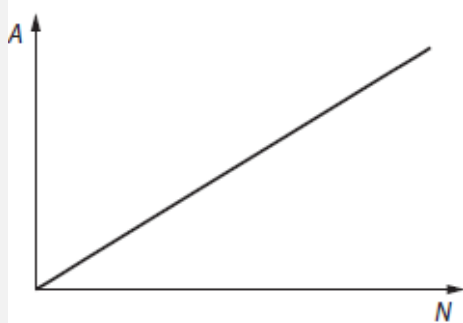

A

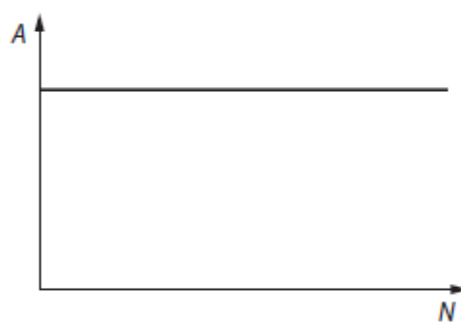

B

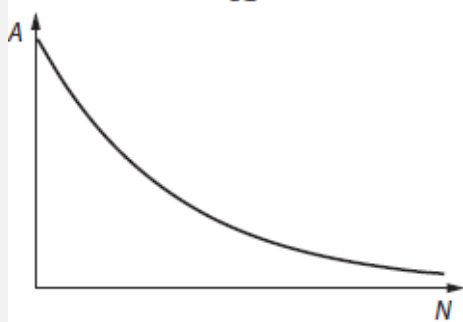

C

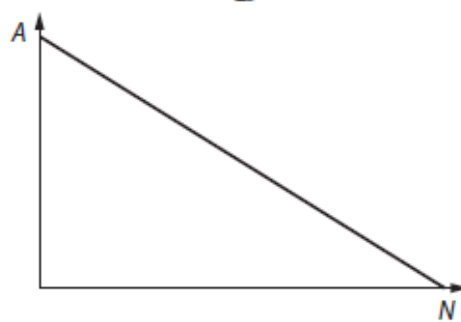

D

76. A radioactive isotope X decays into a stable isotope Y. The decay constant is λ . After a time T the ratio of the number of Y nuclei to the number of X nuclei is 10. No Y nuclei were present initially. From which equation can the correct value of T be determined?

A $\frac{e^{-\lambda T}}{1 - e^{-\lambda T}} = 10$ B $\frac{1 - e^{-\lambda T}}{e^{-\lambda T}} = 10$ C $e^{-\lambda T} = 10$ D $e^{-\lambda T} = \frac{1}{10}$

77. The decay constant of a particular nuclide is λ and $\lambda \ll 1 \text{ s}^{-1}$. There are initially N nuclei of this nuclide present in a sample.

What is the expected number of nuclei that will decay in the next second?

A $Ne^{-\lambda}$ B $N\lambda$ C $\frac{Ne^{-\lambda}}{\ln 2}$ D $\frac{N\lambda}{\ln 2}$

78. Why are deviations from Rutherford scattering observed?

- A The electric force repels the alpha particles before they get too close to the nucleus.
- B The effects of the electrons of the atom are not taken into account.
- C The recoil of the nucleus is not taken into account.
- D The alpha particle gets so close to the nucleus that the strong nuclear force comes into play.

79. Which is evidence for the existence of nuclear energy levels?

- A The short range of the nuclear force.
- B The energies of alpha and gamma particles in radioactive decay.
- C The energies of beta particles in radioactive decay.
- D The emission spectra of gases at low pressure.

80. Which of the indicated nuclear transitions leads to the emission of a gamma ray photon?

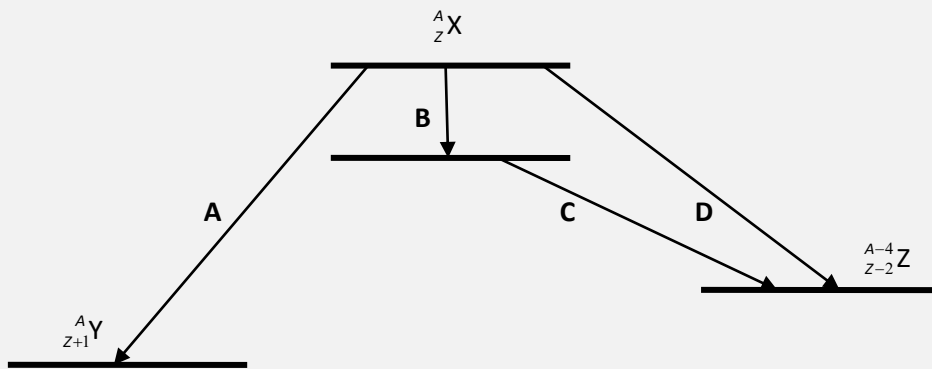

81. Atomic energy levels have a typical energy separation of ΔE_{atomic} . Nuclear energy levels have a typical energy separation of $\Delta E_{\text{nuclear}}$. What is a typical estimate of the ratio $\frac{\Delta E_{\text{nuclear}}}{\Delta E_{\text{atomic}}}$?

- A 10^6
- B 10^3
- C 10^{-3}
- D 10^{-6}

82. Which reaction is a fusion reaction?

- A ${}^{61}_{28}\text{Ni} \rightarrow {}^{61}_{28}\text{Ni} + \gamma$
- B ${}^1_1\text{p} + {}^1_1\text{p} \rightarrow {}^1_1\text{p} + {}^1_1\text{p} + \gamma$
- C ${}^1_1\text{H} + {}^2_1\text{H} \rightarrow {}^3_2\text{He} + \gamma$
- D ${}^{14}_6\text{C} \rightarrow {}^{14}_7\text{N} + {}^0_{-1}\text{e} + \bar{\nu}$

83. The reason high temperatures are required for nuclear fusion is because we have to overcome the
- A electric force barrier.
 - B weak nuclear force barrier
 - C strong nuclear force barrier.
 - D gravitational force barrier.
84. The equilibrium of a main sequence star is achieved through a balance of the gravitational pressure with
- A radiation pressure due to fission reactions.
 - B radiation pressure due to fusion reactions.
 - C electron pressure.
 - D neutron pressure.
85. The common characteristic of main sequence stars is that they
- A have high luminosity.
 - B undergo fusion of hydrogen into helium.
 - C have approximately the same surface temperature.
 - D have approximately the same density.
86. The main factor determining the evolution of a star is
- A its radius.
 - B its density.
 - C its luminosity.
 - D its mass.
87. Star X has a radius R and surface temperature T . Star Y has a radius $\frac{R}{2}$ and surface temperature $2T$.
- What is the ratio of luminosities $\frac{L_x}{L_y}$?
- A $\frac{1}{4}$ B $\frac{1}{2}$ C 2 D 4

88. Stars on the main sequence of the HR diagram are

- A the brightest.
- B the most massive.
- C those fusing helium into carbon.
- D those fusing hydrogen into helium.

89. What is correct as we move up the main sequence from right to left on a standard HR diagram?

- A The density increases.
- B The mass increases.
- C The apparent brightness decreases.
- D The surface temperature decreases.

90. Where would red giant stars be found on this HR diagram?

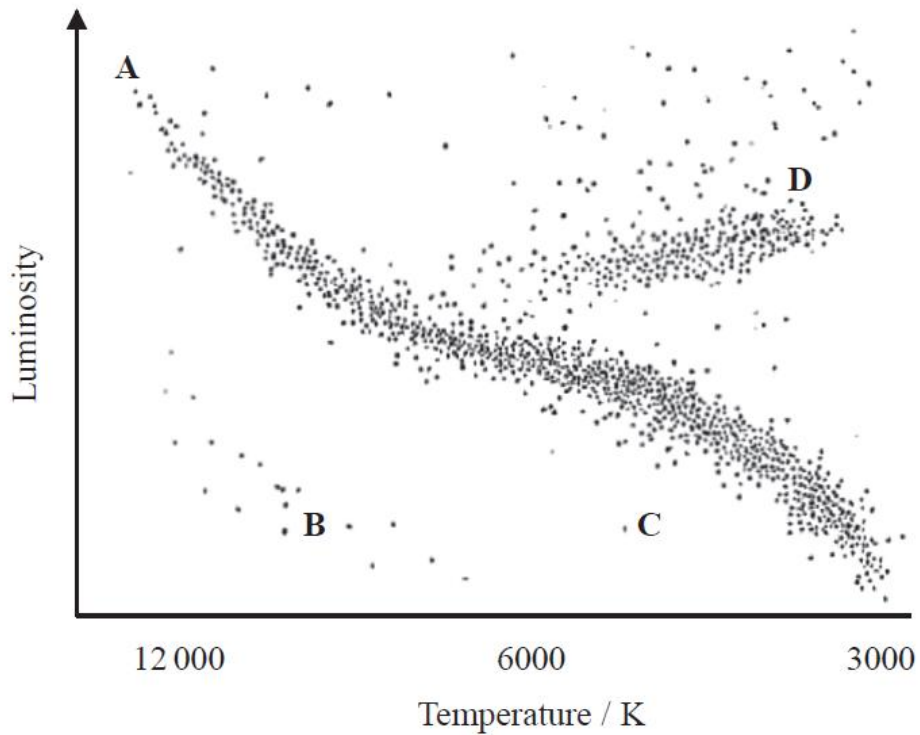

91. A parsec is defined as the distance

- A to the nearest star other than the Sun.
- B at which a star subtending a distance equal to the diameter of the Earth's orbit has parallax 1 arcsec.
- C at which a star subtending a distance equal to the radius of the Earth's orbit has parallax 1 arcsec.
- D at which the apparent brightness of a star is equal to that of the Sun.

92. Stars X and Y have the same surface temperature. Star X has parallax 0.02 arcsec and star Y has parallax 0.08 arcsec. The apparent brightness of star X is four times that of star Y.

What is the ratio $\frac{R_x}{R_y}$, of the radius of star X to that of star Y?

- A 64 B 16 C 8 D 4

93. Two stars X and Y have been marked on this HR diagram.

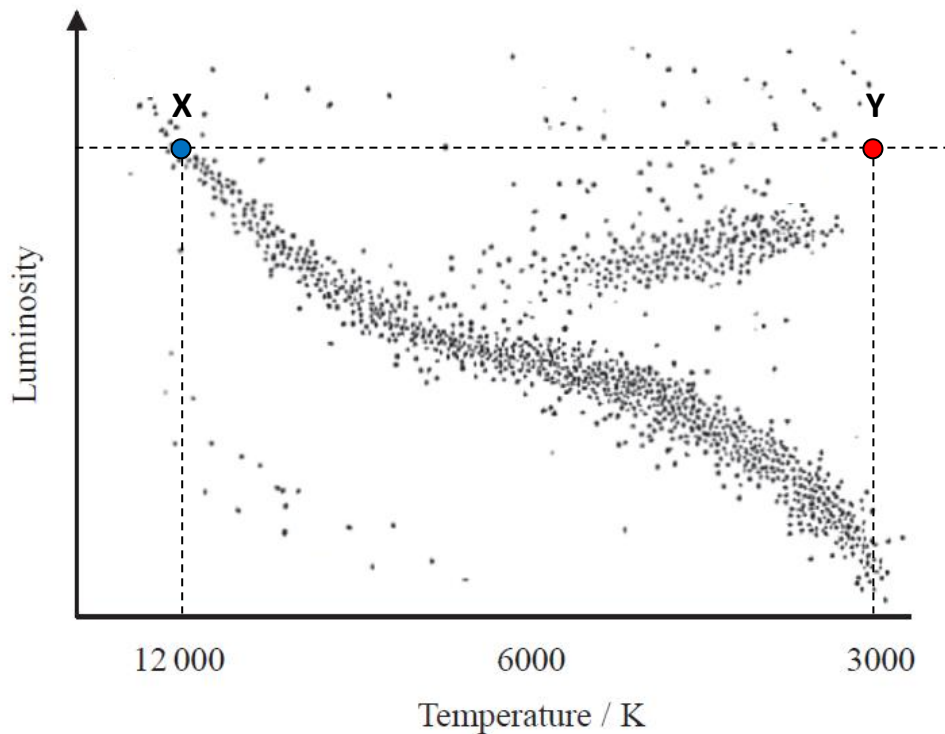

What is the ratio of the radius of Y to that of X, $\frac{R_y}{R_x}$?

- A 4 B 16 C 64 D 256

94. Which diagram shows the evolutionary track of a one solar mass star?

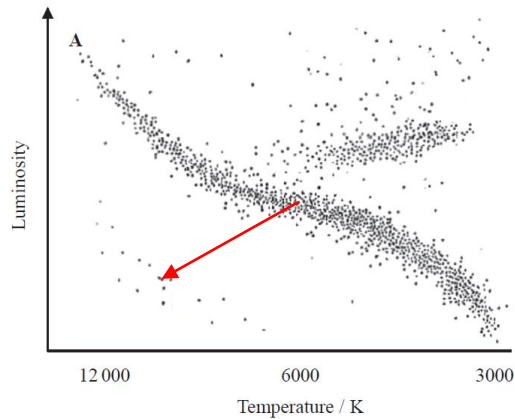

A

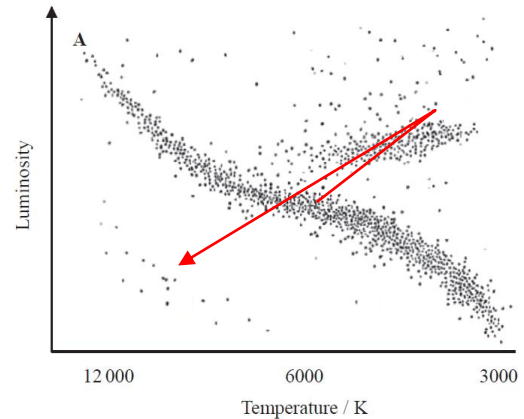

B

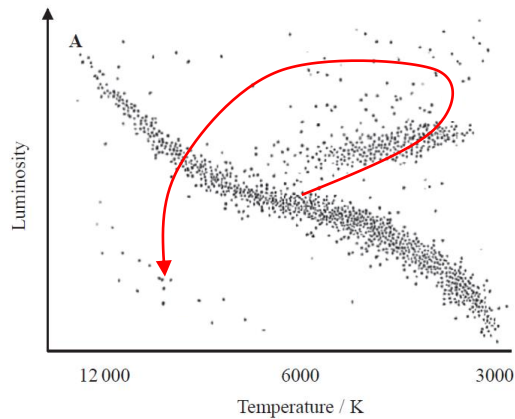

C

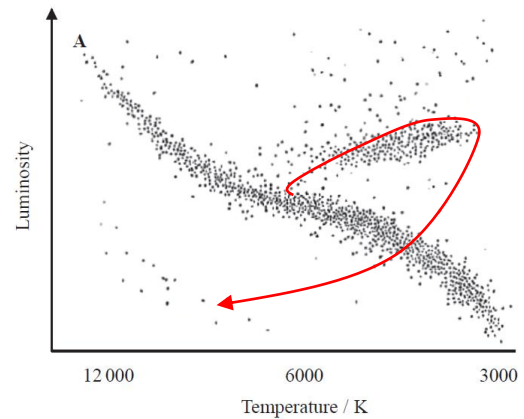

D

95. What is the most likely end stage of a main sequence star of mass equal to 1 solar mass?

- A A white dwarf with a core of helium.
- B A white dwarf with a core of carbon.
- C A neutron star.
- D A black hole.

96. The evolution of 1 solar mass main sequence star involves the stages

- A red giant -> planetary nebula-> white dwarf.
- B red giant -> supernova-> neutron star.
- C red supergiant -> planetary nebula-> white dwarf.
- D red supergiant -> supernova -> neutron star.

97. The Chandrasekhar limit is

- A the mass of a star when it is about to leave the main sequence.
- B the maximum mass of a white dwarf star.
- C the maximum mass of a neutron star.
- D the mass of a red giant star right before the planetary nebula stage.

98. What is correct about a white dwarf?

- A The radiated energy comes from nuclear fusion reactions.
- B The luminosity stays constant.
- C The mass keeps decreasing until the Chandrasekhar limit is reached.
- D The surface temperature keeps decreasing.

99. The density of a neutron star is comparable to the density of

- A water.
- B a nucleus.
- C uranium.
- D the Sun.

100. The spectrum of a star contains the same emission line as a line in the spectrum of the Sun but the wavelength of the line is shorter than the wavelength in the Sun. This is because

- A the star has a higher surface temperature than the Sun.
- B the star has a lower surface temperature than the Sun.
- C the star is moving away from Earth.
- D the star is moving towards Earth.

Topic E

1	B		26	D		51	A		76	B
2	B		27	C		52	C		77	B
3	A		28	B		53	D		78	D
4	C		29	A		54	D		79	B
5	A		30	D		55	B		80	B
6	D		31	D		56	D		81	A
7	A		32	C		57	B		82	C
8	C		33	C		58	D		83	A
9	B		34	D		59	D		84	B
10	D		35	B		60	A		85	B
11	B		36	B		61	D		86	D
12	B		37	A		62	B		87	A
13	A		38	A		63	D		88	D
14	C		39	D		64	A		89	B
15	A		40	A		65	C		90	D
16	A		41	C		66	C		91	C
17	C		42	D		67	A		92	C
18	D		43	C		68	A		93	B
19	A		44	C		69	C		94	C
20	C		45	C		70	B		95	A
21	A		46	B		71	B		96	A
22	B		47	C		72	A		97	B
23	B		48	B		73	B		98	D
24	B		49	D		74	C		99	B
25	A		50	D		75	A		100	D